

CGH55030F

30 W, 5500-5800 MHz, 28V, GaN HEMT for WiMAX

Cree's CGH55030F is a gallium nitride (GaN) high electron mobility transistor (HEMT) designed specifically for high efficiency, high gain and wide bandwidth capabilities, which makes the CGH55030F ideal for 5.5-5.8 GHz WiMAX and BWA amplifier applications. The transistor is supplied in a ceramic/metal flange package. Based on appropriate external match adjustment, the CGH55030F is suitable for 4.9 - 5.5 GHz applications as well.

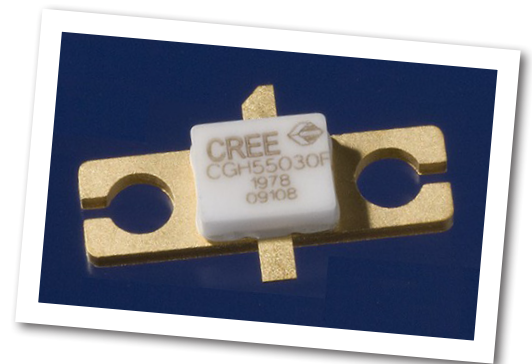

Package Type: 440166
PN: CGH55030F

Typical Performance Over 5.5-5.8GHz ($T_c = 25^\circ\text{C}$) of Demonstration Amplifier

Parameter	5.50 GHz	5.65 GHz	5.80 GHz	Units
Small Signal Gain	9.5	10.0	9.5	dB
EVM at $P_{AVE} = 29\text{ dBm}$	1.1	0.9	0.9	%
EVM at $P_{AVE} = 36\text{ dBm}$	2.2	1.4	1.4	%
Drain Efficiency at $P_{AVE} = 4\text{ W}$	23	24	25	%
Input Return Loss	10.8	22	9.3	dB

Note:

Measured in the CGH55030F-TB amplifier circuit, under 802.16 OFDM, 3.5 MHz Channel BW, 1/4 Cyclic Prefix, 64 QAM Modulated Burst, Symbol Length of 59, Coding Type RS-CC, Coding Rate Type 2/3, PAR = 9.8 dB @ 0.01 % Probability on CCDF.

Features



- 300 MHz Instantaneous Bandwidth
- 30 W Peak Power Capability
- 10 dB Small Signal Gain
- 4 W $P_{AVE} < 2.0\%$ EVM
- 25 % Efficiency at 4 W Average Power
- Designed for WiMAX Fixed Access 802.16-2004 OFDM Applications
- Designed for Multi-carrier DOCSIS Applications

Large Signal Models Available for SiC & GaN



Absolute Maximum Ratings (not simultaneous) at 25 °C Case Temperature

Parameter	Symbol	Rating	Units
Drain-Source Voltage	V_{DSS}	84	Volts
Gate-to-Source Voltage	V_{GS}	-10, +2	Volts
Power Dissipation	P_{DISS}	14	Watts
Storage Temperature	T_{STG}	-55, +150	°C
Operating Junction Temperature	T_J	225	°C
Maximum Forward Gate Current	I_{GMAX}	7.0	mA
Soldering Temperature ¹	T_S	245	°C
Screw Torque	τ	60	in-oz
Thermal Resistance, Junction to Case ²	$R_{\theta JC}$	4.8	°C/W
Case Operating Temperature ²	T_C	-40, +105	°C

Note:

¹ Refer to the Application Note on soldering at www.cree.com/products/wireless_appnotes.asp

² Measured for the CGH55030F at $P_{DISS} = 14$ W

Electrical Characteristics ($T_C = 25^\circ\text{C}$)

Characteristics	Symbol	Min.	Typ.	Max.	Units	Conditions
DC Characteristics¹						
Gate Threshold Voltage	$V_{GS(th)}$	-3.8	-3.3	-2.3	VDC	$V_{DS} = 10$ V, $I_D = 7.2$ mA
Gate Quiescent Voltage	$V_{GS(Q)}$	-	-3.0	-	VDC	$V_{DS} = 28$ V, $I_D = 250$ mA
Saturated Drain Current	I_{DS}	5.8	7.0	-	A	$V_{DS} = 6.0$ V, $V_{GS} = 2$ V
Drain-Source Breakdown Voltage	V_{BR}	84	100	-	VDC	$V_{GS} = -8$ V, $I_D = 7.2$ mA
RF Characteristics^{2,3} ($T_C = 25^\circ\text{C}$, $F_0 = 5.65$ GHz unless otherwise noted)						
Small Signal Gain	G_{SS}	8.5	10.0	-	dB	$V_{DD} = 28$ V, $I_{DQ} = 250$ mA
Drain Efficiency ⁴	η	19	24	-	%	$V_{DD} = 28$ V, $I_{DQ} = 250$ mA, $P_{AVE} = 4$ W
Back-Off Error Vector Magnitude	EVM_1	-	2.5	-	%	$V_{DD} = 28$ V, $I_{DQ} = 250$ mA, $P_{AVE} = 29$ dBm
Error Vector Magnitude	EVM_2	-	2.0	-	%	$V_{DD} = 28$ V, $I_{DQ} = 250$ mA, $P_{AVE} = 4$ W
Output Mismatch Stress	VSWR	-	10:1	-	Ψ	No damage at all phase angles, $V_{DD} = 28$ V, $I_{DQ} = 250$ mA, $P_{AVE} = 4$ W
Dynamic Characteristics						
Input Capacitance	C_{GS}	-	9.3	-	pF	$V_{DS} = 28$ V, $V_{GS} = -8$ V, $f = 1$ MHz
Output Capacitance	C_{DS}	-	2.0	-	pF	$V_{DS} = 28$ V, $V_{GS} = -8$ V, $f = 1$ MHz
Feedback Capacitance	C_{GD}	-	0.9	-	pF	$V_{DS} = 28$ V, $V_{GS} = -8$ V, $f = 1$ MHz

Notes:

¹ Measured on wafer prior to packaging.

² Measured in the CGH55030F-TB test fixture.

³ Under 802.16 OFDM, 3.5 MHz Channel BW, 1/4 Cyclic Prefix, 64 QAM Modulated Burst, 5 ms Burst, Symbol Length of 59, Coding Type RS-CC, Coding Rate Type 2/3, PAR = 9.8 dB @ 0.01 % Probability on CCDF.

⁴ Drain Efficiency = P_{OUT} / P_{DC}

Typical WiMAX Performance

Small Signal S-Parameters vs Frequency of CGH55030F in the CGH55030F-TB
 $V_{DD} = 28\text{ V}$, $I_{DQ} = 250\text{ mA}$

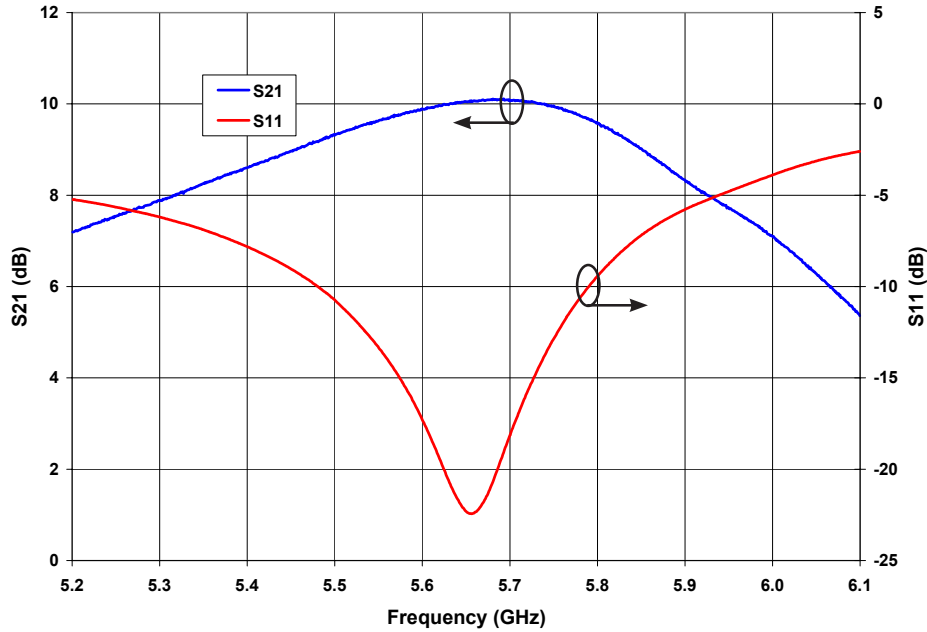

Typical EVM and Efficiency versus Frequency of CGH55030F in the CGH55030F-TB
 $V_{DD} = 28\text{ V}$, $I_{DQ} = 250\text{ mA}$, 802.16-2004 OFDM, PAR=9.8 dB, $P_{AVE} = 5\text{ W}$

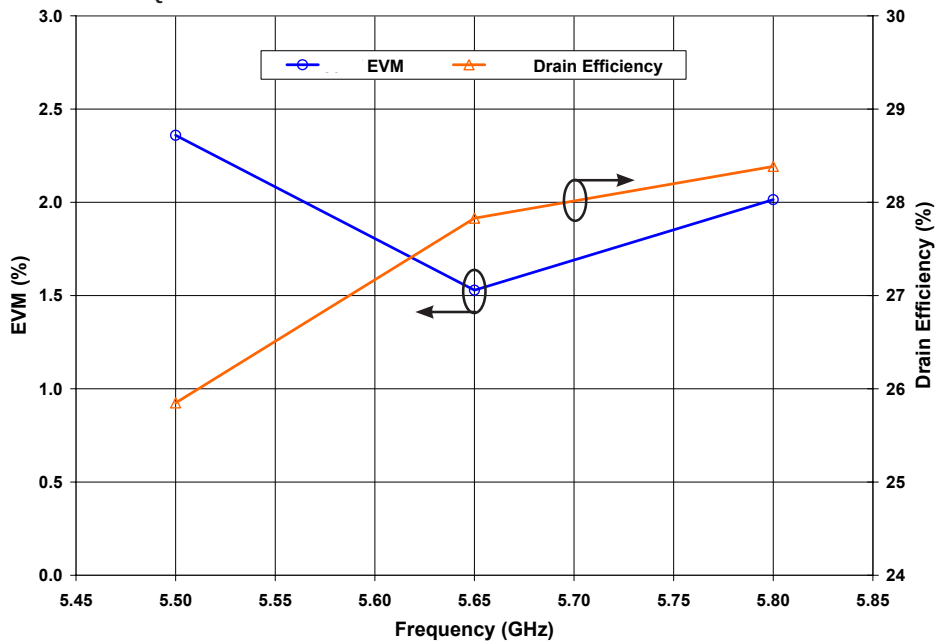

Note:

Under 802.16 OFDM, 3.5 MHz Channel BW, 1/4 Cyclic Prefix, 64 QAM Modulated Burst, Symbol Length of 59, Coding Type RS-CC, Coding Rate Type 2/3, PAR = 9.8 dB @ 0.01 % Probability on CCDF.

Typical WiMAX Performance

Drain Efficiency and Gain vs Output Power of CGH55030F in CGH55030F-TB
 $V_{DD} = 28\text{ V}$, $I_{DQ} = 250\text{ mA}$, 802.16-2004 OFDM, PAR=9.8 dB

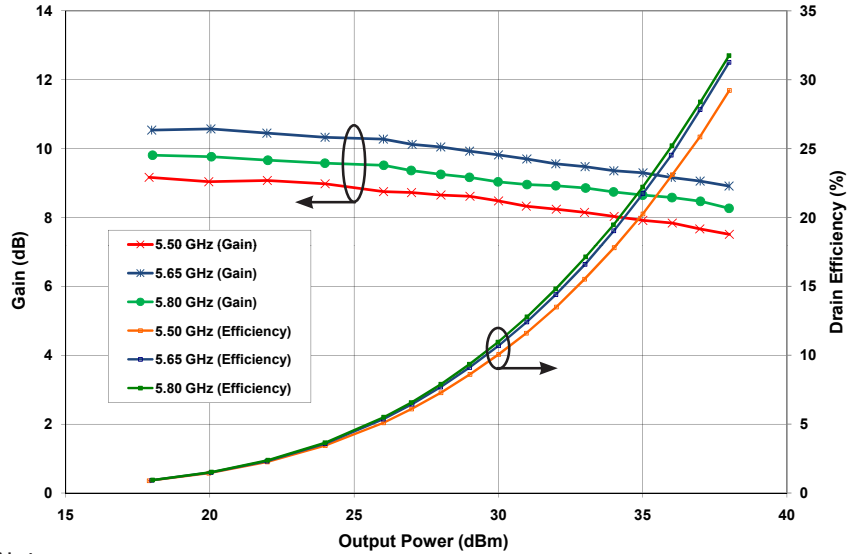

Note:

Under 802.16 OFDM, 3.5 MHz Channel BW, 1/4 Cyclic Prefix, 64 QAM Modulated Burst, Symbol Length of 59, Coding Type RS-CC, Coding Rate Type 2/3, PAR = 9.8 dB @ 0.01 % Probability on CCDF.

Typical EVM and Drain Efficiency vs Output Power of CGH55030F in CGH55030F-TB at 5.50GHz, 5.65 GHz, 5.80GHz, 802.16-2004 OFDM, PAR=9.8 dB

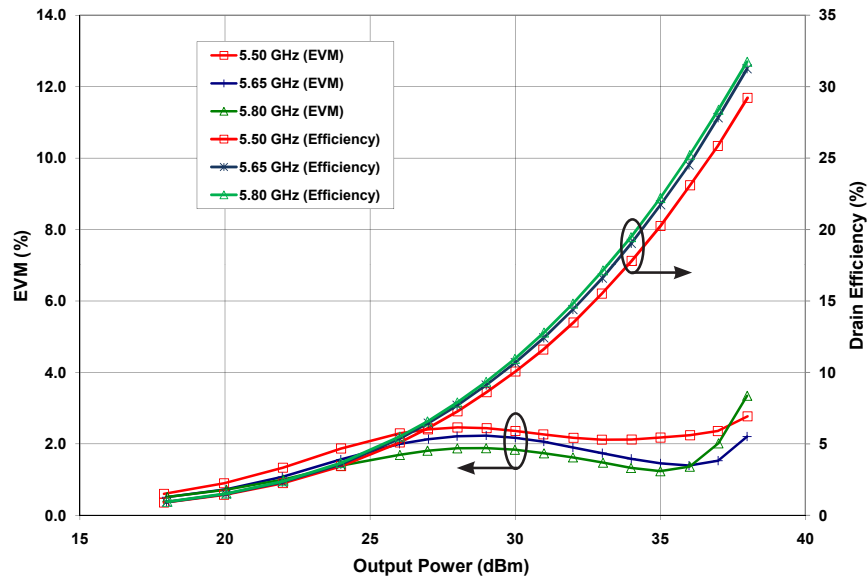

Note:

Under 802.16 OFDM, 3.5 MHz Channel BW, 1/4 Cyclic Prefix, 64 QAM Modulated Burst, Symbol Length of 59, Coding Type RS-CC, Coding Rate Type 2/3, PAR = 9.8 dB @ 0.01 % Probability on CCDF.



Typical DOCSIS Performance

Modulation Error Ratio vs Power Output of CGH55030F in Broadband Amplifier Circuit

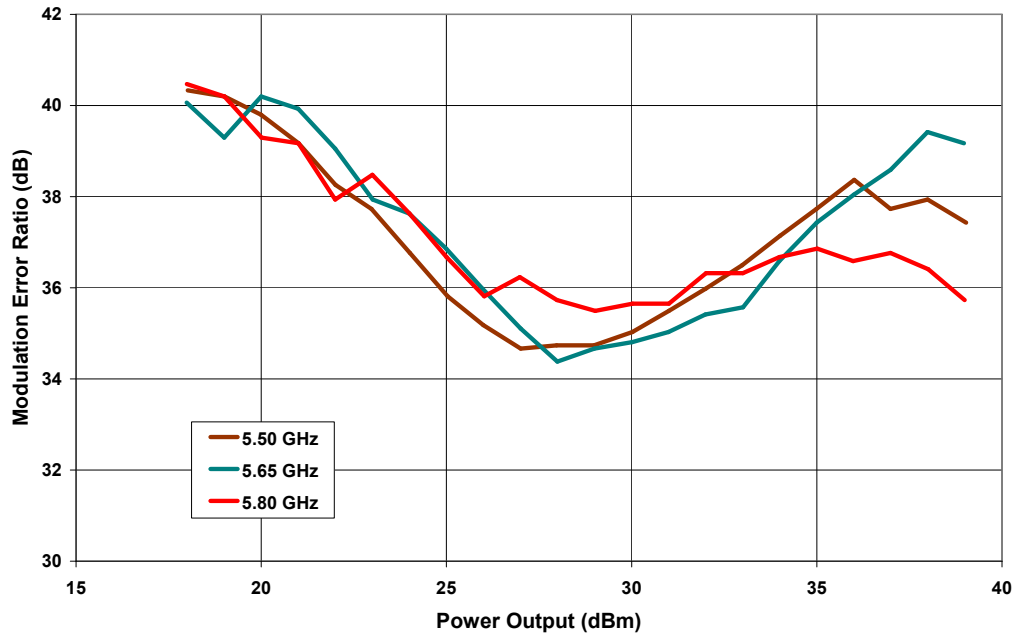

Note:

MER is the metric of choice for cable systems and can be related to EVM by the following equation: $EVM(\%) = 100 \times 10^{-((MER_{dB} + MTA_{dB})/20)}$. MTA is the "maximum-to-average constellation power ratio" which varies with the modulation type: MTA = 0 for BPSK and QPSK; 2.55 for 16QAM and 8QAM-DS; 3.68 for 64QAM and 32QAM-DS; 4.23 for 256QAM and 128QAM-DS

EVM vs Output Power of CGH55030F in Broadband Amplifier Circuit

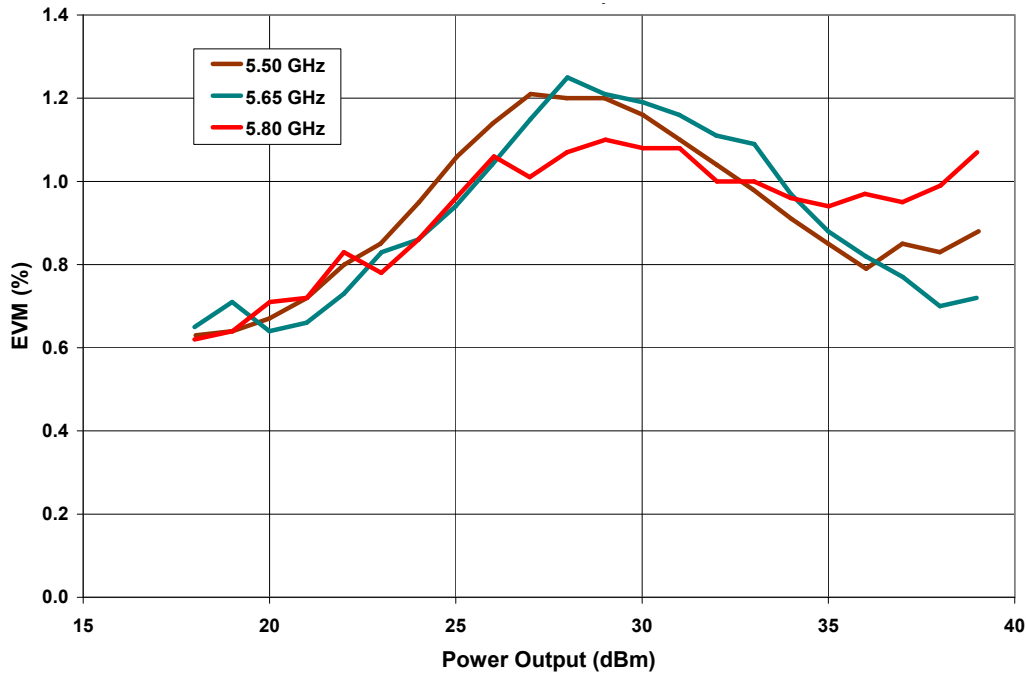

Note:

Under DOCSIS, 6.0 MHz Channel BW, 64 QAM, PN23, Filter Alpha 0.18, PAR = 6.7dB.

Source and Load Impedances

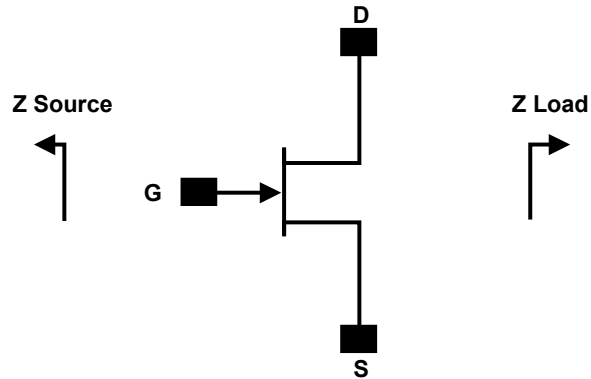

Frequency (MHz)	Z Source	Z Load
5500	8.0 - j12.4	13.2 - j12.2
5650	8.7 - j13.1	13.8 - j11.4
5800	8.4 - j14.0	14.4 - j10.7

Note 1. $V_{DD} = 28V$, $I_{DQ} = 250$ mA in the 440166 package.

Note 2. Impedences are extracted from the CGH55030F-TB demonstration amplifier and are not source and load pull data derived from the transistor.

CGH55030F-TB Demonstration Amplifier Circuit Bill of Materials

Designator	Description	Qty
R1	RES, 1/16W, 0603, 1%, 562 OHMS	1
R2	RES, 1/16W, 0603, 1%, 22.6 OHMS	1
C2	CAP, 0.3pF, +/-0.05pF, 0402, ATC600L	1
C16	CAP, 33 UF, 20%, G CASE	1
C15	CAP, 1.0UF, 100V, 10%, X7R, 1210	1
C8	CAP 10UF 16V TANTALUM	1
C9	CAP, 0.4pF, +/-0.05pF, 0603, ATC600S	1
C1	CAP, 1.2pF, +/-0.1pF, 0603, ATC600S	1
C6,C13	CAP,200 PF,0603 PKG, 100 V	2
C4,C11	CAP, 10.0pF,+/-5%, 0603, ATC600S	2
C5,C12	CAP, 39pF, +/-5%, 0603, ATC600S	2
C7,C14	CAP, 330000PF, 0805, 100V, TEMP STABILIZ	2
J3,J4	CONN, SMA, PANEL MOUNT JACK, FLANGE	2
J1	HEADER RT>PLZ .1CEN LK 5POS	1
-	PCB, RO4350B, Er = 3.48, h = 20 mil	1
-	CGH55030F	1

CGH55030F-TB Demonstration Amplifier Circuit

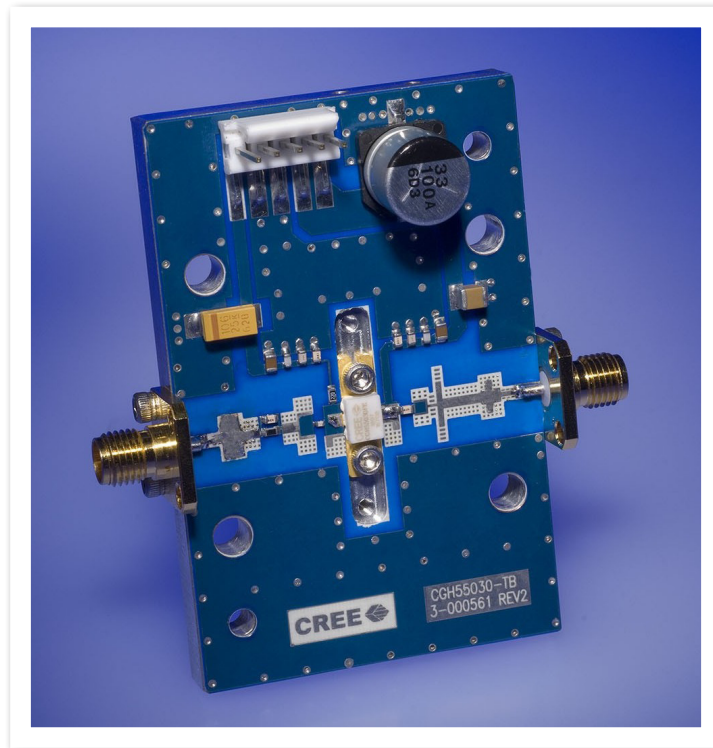

CGH55030F-TB Demonstration Amplifier Circuit Schematic

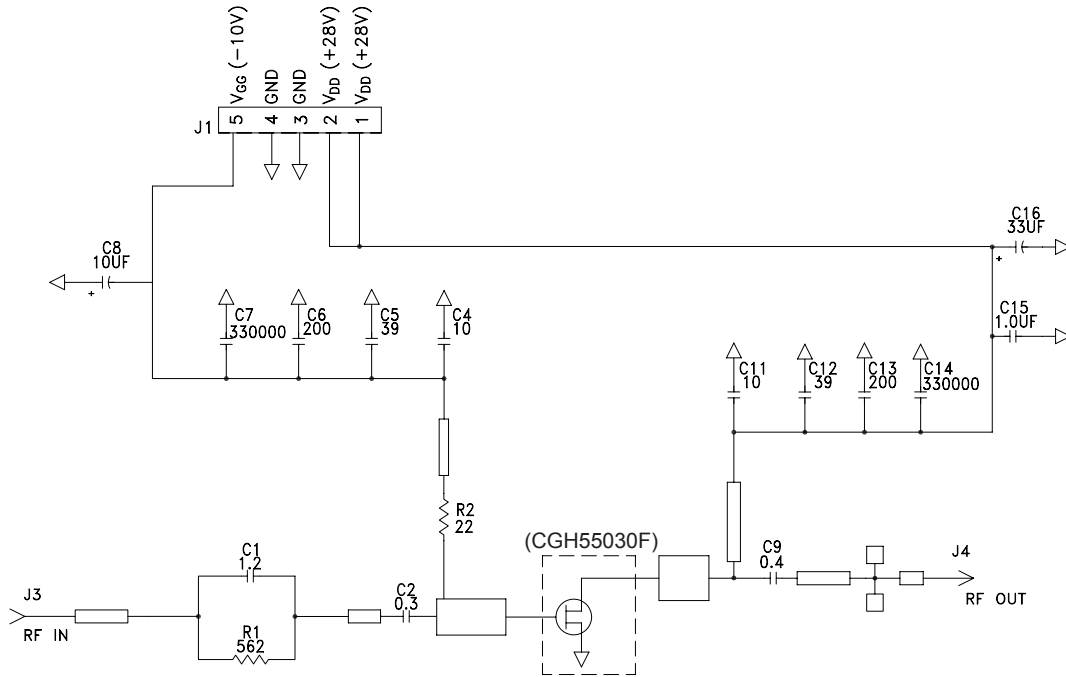

CGH55030F-TB Demonstration Amplifier Circuit Outline

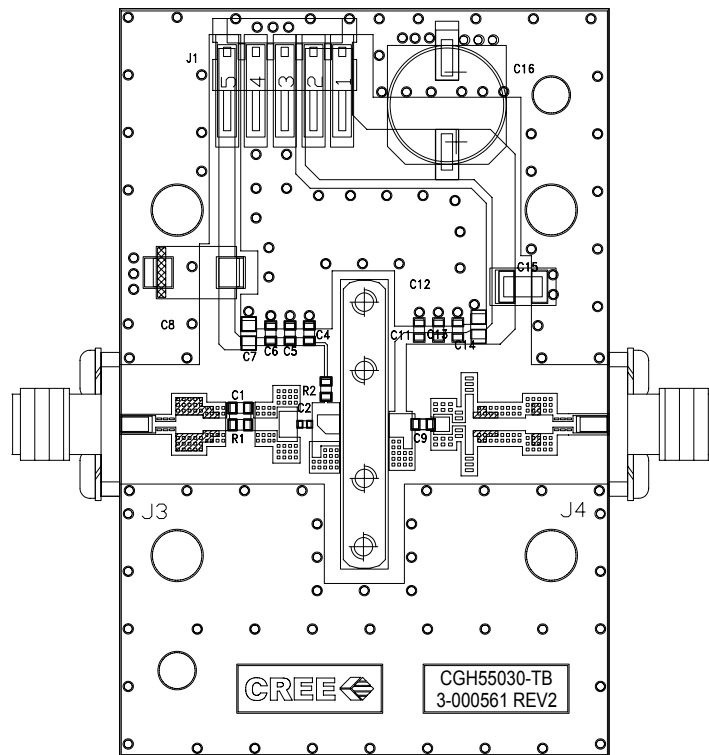



Typical Package S-Parameters for CGH55030F
(Small Signal, $V_{DS} = 28\text{ V}$, $I_{DQ} = 250\text{ mA}$, angle in degrees)

Frequency	Mag S11	Ang S11	Mag S21	Ang S21	Mag S12	Ang S12	Mag S22	Ang S22
500 MHz	0.914	-163.42	12.17	89.92	0.021	5.48	0.528	-163.71
600 MHz	0.914	-167.32	10.17	86.47	0.021	3.15	0.531	-166.13
700 MHz	0.914	-170.31	8.73	83.46	0.021	1.28	0.534	-167.86
800 MHz	0.913	-172.73	7.65	80.72	0.021	-0.30	0.537	-169.14
900 MHz	0.913	-174.76	6.80	78.18	0.021	-1.68	0.540	-170.15
1.0 GHz	0.914	-176.53	6.11	75.78	0.021	-2.91	0.544	-170.97
1.1 GHz	0.914	-178.09	5.55	73.47	0.021	-4.03	0.547	-171.66
1.2 GHz	0.914	-179.52	5.08	71.24	0.021	-5.04	0.551	-172.26
1.3 GHz	0.914	179.17	4.69	69.08	0.020	-5.98	0.555	-172.80
1.4 GHz	0.915	177.95	4.35	66.96	0.020	-6.84	0.559	-173.30
1.5 GHz	0.915	176.79	4.05	64.89	0.020	-7.63	0.563	-173.77
1.6 GHz	0.915	175.68	3.79	62.86	0.020	-8.37	0.567	-174.23
1.7 GHz	0.916	174.62	3.56	60.85	0.020	-9.04	0.571	-174.68
1.8 GHz	0.916	173.60	3.36	58.88	0.020	-9.66	0.576	-175.13
1.9 GHz	0.916	172.60	3.18	56.93	0.019	-10.22	0.580	-175.59
2.0 GHz	0.917	171.62	3.01	55.00	0.019	-10.72	0.585	-176.05
2.1 GHz	0.917	170.67	2.86	53.09	0.019	-11.16	0.590	-176.52
2.2 GHz	0.918	169.72	2.73	51.21	0.019	-11.54	0.595	-177.01
2.3 GHz	0.918	168.79	2.60	49.34	0.019	-11.87	0.599	-177.51
2.4 GHz	0.919	167.87	2.49	47.49	0.018	-12.13	0.604	-178.03
2.5 GHz	0.919	166.95	2.39	45.66	0.018	-12.33	0.609	-178.56
2.6 GHz	0.919	166.04	2.29	43.84	0.018	-12.46	0.614	-179.11
2.7 GHz	0.920	165.13	2.20	42.03	0.018	-12.53	0.619	-179.68
2.8 GHz	0.920	164.22	2.12	40.24	0.017	-12.53	0.623	179.74
2.9 GHz	0.921	163.31	2.04	38.47	0.017	-12.46	0.628	179.13
3.0 GHz	0.921	162.41	1.97	36.70	0.017	-12.32	0.633	178.51
3.2 GHz	0.922	160.58	1.85	33.21	0.017	-11.83	0.642	177.22
3.4 GHz	0.923	158.73	1.73	29.76	0.016	-11.04	0.650	175.85
3.6 GHz	0.923	156.87	1.63	26.34	0.016	-9.97	0.659	174.42
3.8 GHz	0.924	154.97	1.55	22.96	0.016	-8.61	0.666	172.93
4.0 GHz	0.924	153.04	1.47	19.61	0.016	-7.01	0.674	171.37
4.2 GHz	0.925	151.06	1.40	16.29	0.016	-5.19	0.681	169.74
4.4 GHz	0.925	149.04	1.34	12.98	0.016	-3.21	0.688	168.06
4.6 GHz	0.925	146.97	1.28	9.68	0.016	-1.14	0.694	166.32
4.8 GHz	0.926	144.85	1.23	6.39	0.016	0.95	0.699	164.51
5.0 GHz	0.926	142.66	1.19	3.11	0.017	2.98	0.705	162.64
5.2 GHz	0.926	140.41	1.15	-0.18	0.018	4.88	0.709	160.70
5.4 GHz	0.926	138.08	1.11	-3.48	0.018	6.58	0.714	158.70
5.6 GHz	0.925	135.68	1.08	-6.79	0.019	8.03	0.717	156.63
5.8 GHz	0.925	133.19	1.05	-10.13	0.020	9.19	0.721	154.49
6.0 GHz	0.925	130.62	1.02	-13.50	0.022	10.03	0.724	152.27

Download this s-parameter file in ".s2p" format at http://www.cree.com/products/wireless_s-parameters.asp



Product Dimensions CGH55030F (Package Type — 440166)

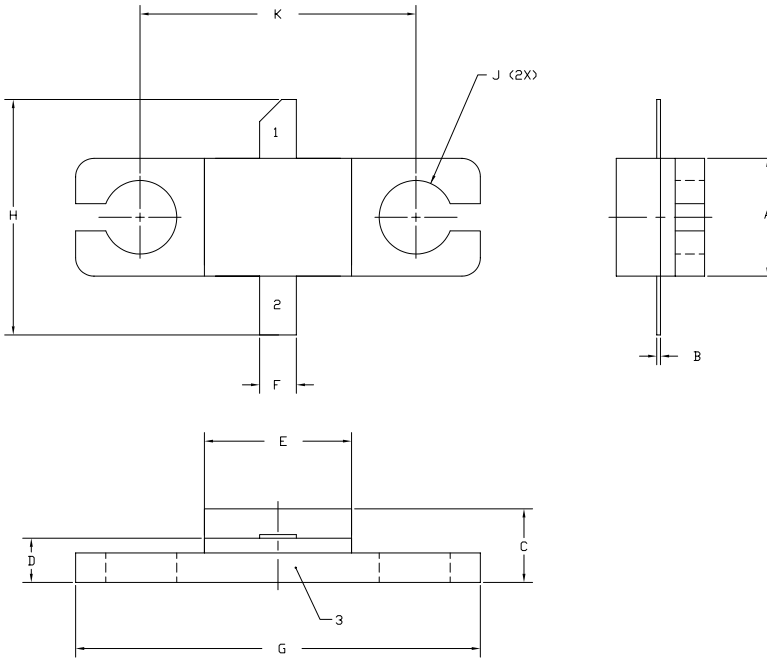

- NOTES:
1. DIMENSIONING AND TOLERANCING PER ANSI Y14.5M, 1982.
 2. CONTROLLING DIMENSION: INCH.
 3. ADHESIVE FROM LID MAY EXTEND A MAXIMUM OF 0.020" BEYOND EDGE OF LID.
 4. LID MAY BE MISALIGNED TO THE BODY OF THE PACKAGE BY A MAXIMUM OF 0.008" IN ANY DIRECTION.
 5. ALL PLATED SURFACES ARE Ni/AU

DIM	INCHES		MILLIMETERS	
	MIN	MAX	MIN	MAX
A	0.155	0.165	3.94	4.19
B	0.004	0.006	0.10	0.15
C	0.115	0.135	2.92	3.43
D	0.057	0.067	1.45	1.70
E	0.195	0.205	4.95	5.21
F	0.045	0.055	1.14	1.40
G	0.545	0.555	13.84	14.09
H	0.280	0.360	7.87	8.38
J	ø .100		2.54	
K	0.375		9.53	

PIN 1. GATE
 PIN 2. DRAIN
 PIN 3. SOURCE



Disclaimer

Specifications are subject to change without notice. Cree, Inc. believes the information contained within this data sheet to be accurate and reliable. However, no responsibility is assumed by Cree for any infringement of patents or other rights of third parties which may result from its use. No license is granted by implication or otherwise under any patent or patent rights of Cree. Cree makes no warranty, representation or guarantee regarding the suitability of its products for any particular purpose. "Typical" parameters are the average values expected by Cree in large quantities and are provided for information purposes only. These values can and do vary in different applications and actual performance can vary over time. All operating parameters should be validated by customer's technical experts for each application. Cree products are not designed, intended or authorized for use as components in applications intended for surgical implant into the body or to support or sustain life, in applications in which the failure of the Cree product could result in personal injury or death or in applications for planning, construction, maintenance or direct operation of a nuclear facility.

For more information, please contact:

Cree, Inc.
4600 Silicon Drive
Durham, NC 27703
www.cree.com/wireless

Ryan Baker
Marketing
Cree, Wireless Devices
919.287.7816

Tom Dekker
Sales Director
Cree, Wireless Devices
919.313.5639